

01 SVILUPPARE UN DIVANO

VISUALIZZA	STRUMENTI UTILIZZATI	
<p>Per iniziare</p> <p>Viste</p>  <p>3D, alto, davanti, destro, dietro, sinistra</p>	<p>Rettangolo</p> 	<p>Spingi e tira</p> 
	<p>Arco</p> 	<p>Riempi</p> 
	<p>Zoom</p> 	<p>Orbita</p> 
	<p>Panoramica</p> 	

Avviare il programma attivare la modalità vista e selezionare modalità Alto



Disegnare con lo strumento rettangolo una figura di dimensioni 210;90 (digitare il valore nella finestra in basso a destra) e quindi aggiungere i rettangolo per braccioli e schienale.

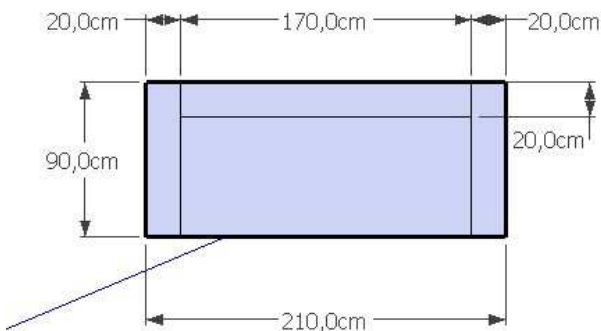

Selezionare modalità vista Iso (3D) selezionare i rettangolo e utilizzando lo strumento spingi/tira inizia ad estrarre i volumi con le seguenti altezze: seduta 40 cm bracciolo 60 cm schienale 90 cm

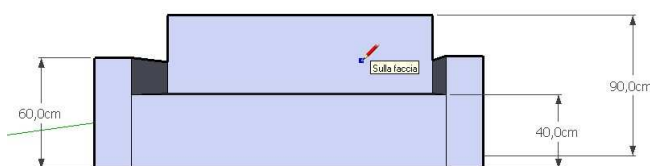
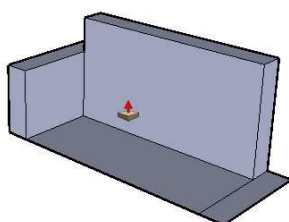

Fino ad ottenere un solido come questo:

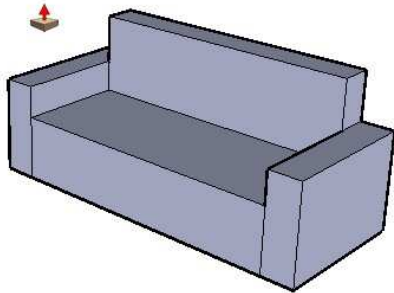

Portarsi in modalità vista "davanti" ed inserire sulla sommità del bracciolo un arco di raggio 10 cm (utilizzare lo strumento arco)



Selezionare modalità vista Iso (3D) ed estrarre il bracciolo

Compiere la stessa operazione sulla parte alta dell schienale

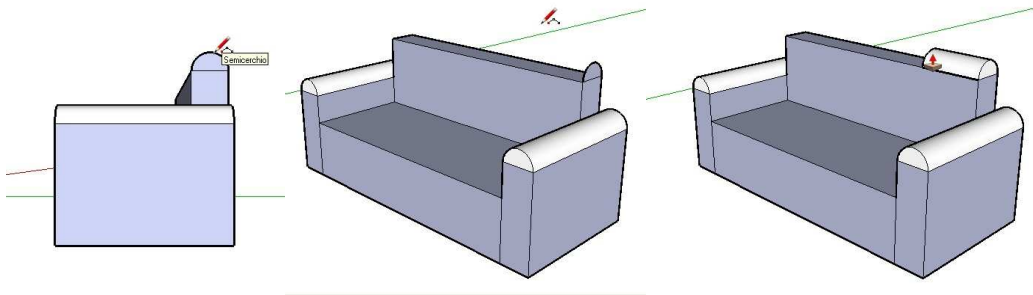

Utilizzando lo strumento "riempi" e selezionando come riempimento tappetie tessuti colorare il divano.

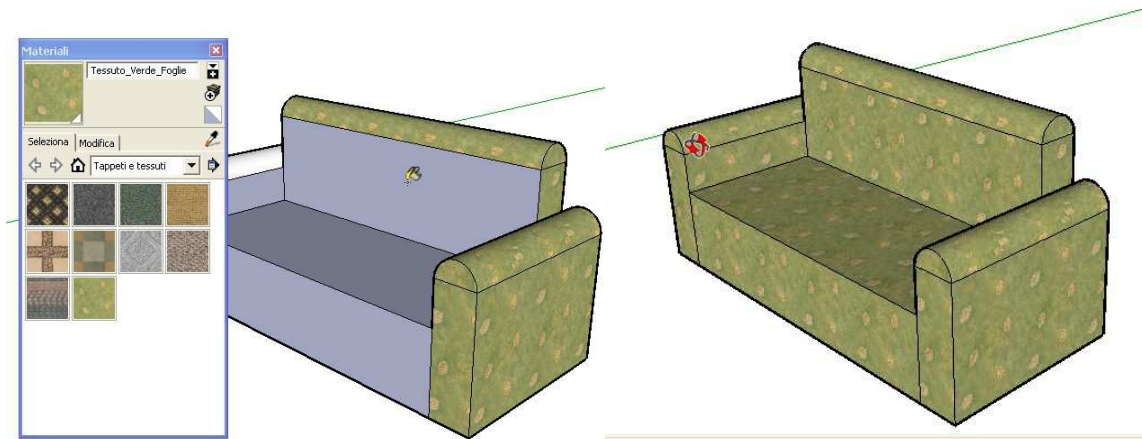

Salvate nella cartella disegno SG con nome SG01